

CONNECTION	SIGNAL	DESCRIPTION
J7+	+5 VDC	+5DC Output
J7-	GND	Ground
J5 +	CMD1	The command for solenoid #1 should be connected to this pin. The voltage across the solenoid # 1 is proportional to this voltage. The range of the input is zero to +5 VDC.
J5 -	GND	This pin may be used as the return for IN1.
J6 +	CMD2	The command for solenoid #2 should be connected to this pin. The voltage across the solenoid # 2 is proportional to this voltage. The range of the input is zero to +5 VDC.
J6 -	GND	This pin may be used as the return for IN2.
J1 +	PWR	This pin should be connected to the positive output of the driver power supply. The maximum voltage applied should not exceed +50 VDC.
J1 -	GND	This pin should be connected to the negative output of the driver power supply.
J2 +	PWR	This pin should be connected to one terminal of solenoid #1.
J2 -	SOL1	This pin should be connected to the other terminal of solenoid #1.
J3 +	PWR	This pin should be connected to one terminal of solenoid #2.
J3 -	SOL2	This pin should be connected to the other terminal of solenoid #2.

### PWM - xx Pin Assignment and Description



**Optimal Engineering Systems, Inc.**  
 6901 Woodley Avenue  
 Van Nuys, California 91406 U.S.A.  
[www.oesincorp.com](http://www.oesincorp.com)

+1 (818) 222-9200  
 FAX +1 (818) 222-9580  
 E-mail [sales@oesincorp.com](mailto:sales@oesincorp.com)

## Warning:

Handling the PWM Module shall be performed in a static safe environment while a ground strap is used. Damages arising due to not observing the static pre-cautions shall void the limited ninety-day warranty.

Command Range:

0 to +5 VDC

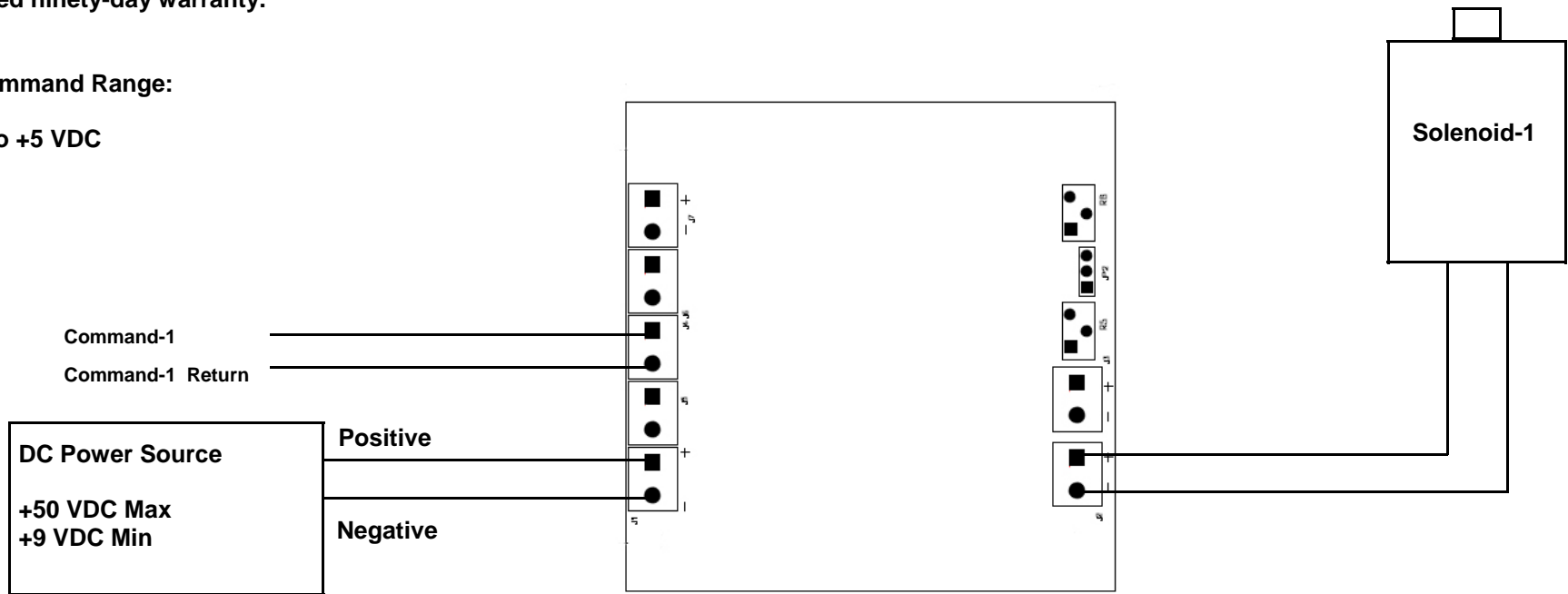

**PWM - 01 Wiring Diagram**

R5 potentiometer adjusts the maximum duty cycle of solenoid-1. Turning R5 CCW increases the maximum duty cycle.

Using a voltmeter, measure the voltage of JP2-1 (closer to R5) respect to JP2-2 (middle pin), this is the output of R5 potentiometer. The scale is 20% duty cycle per Volt. If it is set at 2.5 Volts, the maximum duty cycle will be 50%.



**Optimal Engineering Systems, Inc.**  
6901 Woodley Avenue  
Van Nuys, California 91406 U.S.A.  
[www.oesincorp.com](http://www.oesincorp.com)

+1 (818) 222-9200  
FAX +1 (818) 222-9580  
E-mail [sales@oesincorp.com](mailto:sales@oesincorp.com)

## Warning:

Handling the PWM Module shall be performed in a static safe environment while a ground strap is used. Damages arising due to not observing the static pre-cautions shall void the limited ninety-day warranty.

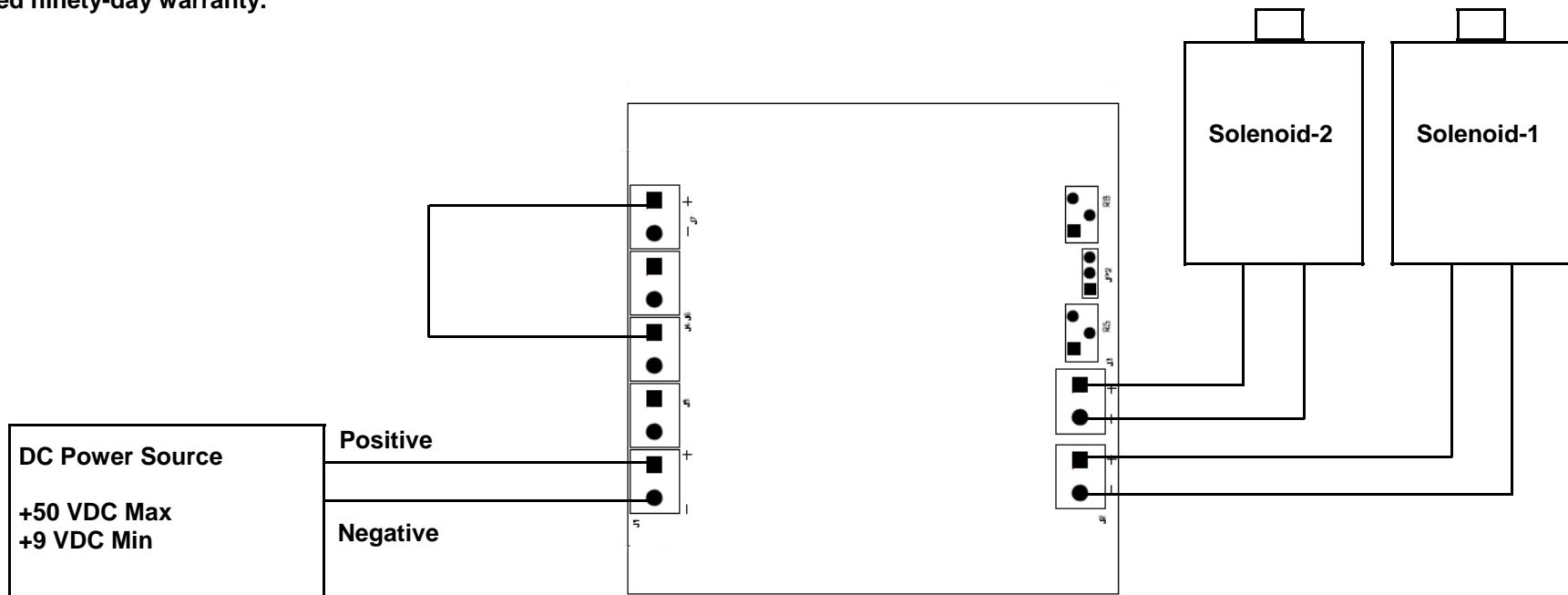

**PWM - 01 Wiring Diagram, No External Signal Is Required**

R5 potentiometer adjusts the maximum duty cycle of solenoid-1. Turning R5 CCW increases the maximum duty cycle.

Using a voltmeter, measure the voltage of JP2-1 (closer to R5) respect to JP2-2 (middle pin), this is the output of R5 potentiometer. The scale is 20% duty cycle per Volt. If it is set at 2.5 Volts, the maximum duty cycle will be 50%.



*Optimal Engineering Systems, Inc.*  
6901 Woodley Avenue  
Van Nuys, California 91406 U.S.A.  
[www.oesincorp.com](http://www.oesincorp.com)

+1 (818) 222-9200  
FAX +1 (818) 222-9580  
E-mail [sales@oesincorp.com](mailto:sales@oesincorp.com)

**Warning:**

Handling the PWM Module shall be performed in a static safe environment while a ground strap is used. Damages arising due to not observing the static pre-cautions shall void the limited ninety-day warranty.

**Command Range:**

**0 to +5 VDC**

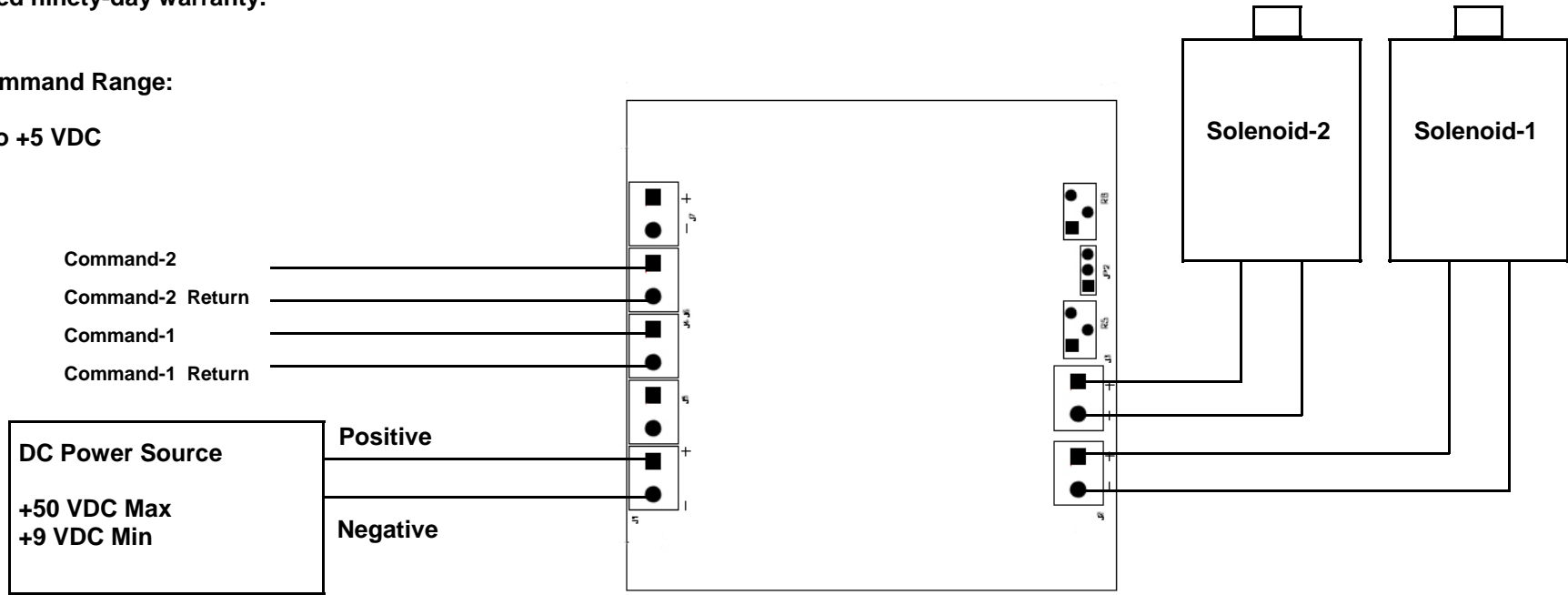

**PWM - 02 Wiring Diagram**

R5 potentiometer adjusts the maximum duty cycle of solenoid-1. Turning R5 CCW increases the maximum duty cycle.

Using a voltmeter, measure the voltage of JP2-1 (closer to R5) respect to JP2-2 (middle pin), this is the output of R5 potentiometer. The scale is 20% duty cycle per Volt. If it is set at 2.5 Volts, the maximum duty cycle will be 50%.

R6 potentiometer adjusts the maximum duty cycle of solenoid-2. Turning R6 CCW increases the maximum duty cycle.

Using a voltmeter, measure the voltage of JP2-3 (closer to R6) respect to JP2-2 (middle pin), this is the output of R6 potentiometer. The scale is 20% duty cycle per Volt. If it is set at 2.5 Volts, the maximum duty cycle will be 50%.



**Optimal Engineering Systems, Inc.**  
6901 Woodley Avenue  
Van Nuys, California 91406 U.S.A.  
www.oesincorp.com

+1 (818) 222-9200  
FAX +1 (818) 222-9580  
E-mail sales@oesincorp.com

## Warning:

Handling the PWM Module shall be performed in a static safe environment while a ground strap is used. Damages arising due to not observing the static pre-cautions shall void the limited ninety-day warranty.

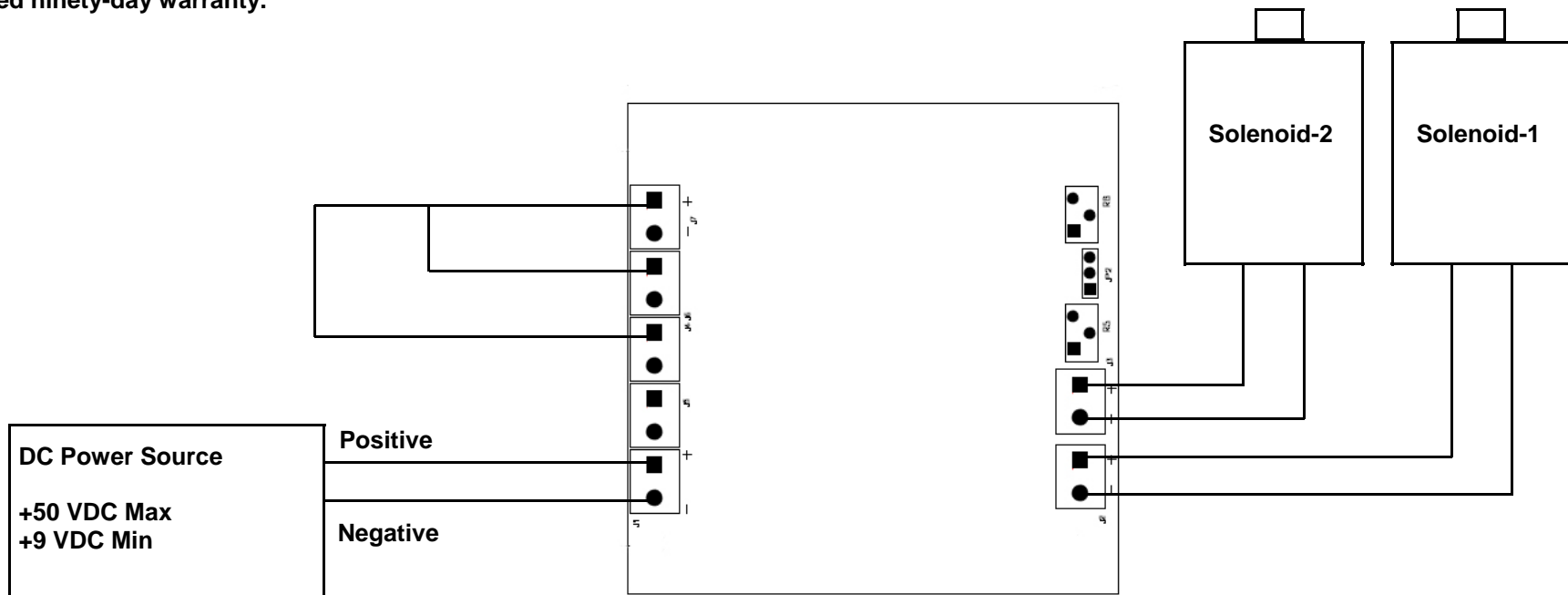

**PWM - 02 Wiring Diagram, No External Signal Is Required**

R5 potentiometer adjusts the maximum duty cycle of solenoid-1. Turning R5 CCW increases the maximum duty cycle.

Using a voltmeter, measure the voltage of JP2-1 (closer to R5) respect to JP2-2 (middle pin), this is the output of R5 potentiometer. The scale is 20% duty cycle per Volt. If it is set at 2.5 Volts, the maximum duty cycle will be 50%.

R6 potentiometer adjusts the maximum duty cycle of solenoid-2. Turning R6 CCW increases the maximum duty cycle.

Using a voltmeter, measure the voltage of JP2-3 (closer to R6) respect to JP2-2 (middle pin), this is the output of R6 potentiometer. The scale is 20% duty cycle per Volt. If it is set at 2.5 Volts, the maximum duty cycle will be 50%.



**Optimal Engineering Systems, Inc.**  
6901 Woodley Avenue  
Van Nuys, California 91406 U.S.A.  
[www.oesincorp.com](http://www.oesincorp.com)

+1 (818) 222-9200  
FAX +1 (818) 222-9580  
E-mail [sales@oesincorp.com](mailto:sales@oesincorp.com)